

Revision No 12 to Supplement ref. 8.9 is approved by CAA under approval number UK.MAJ.00002 on 20 April 2021.
Validated by EASA under approval number 10076595

8.9 KUBÍČEK 'BOTTOM ENDS' WITH CAMERON ENVELOPES

8.9.1 GENERAL INFORMATION

This supplement shall be inserted in the Flight Manual, in Section 8: 'Supplements' with the revisions record sheet amended accordingly.

Information contained herein supplements, or in the case of conflict, supersedes that contained in the basic Flight Manual. For Limitations, Procedures, and Performance Data not contained in this supplement, consult the basic Hot Air Balloon Flight Manual.

All references to the Kubíček Flight Manual refers to Flight manual Ref B.3102, Revision 10 dated 20-August 2020 or later EASA approved revision.

Throughout this supplement the term "Cameron" refers to envelopes, burners and cylinders manufactured by Cameron, Lindstrand Hot Air Balloons Limited, Sky and Thunder & Colt.

Issue 12 of this supplement has twelve pages

Supplement 7.9 to Maintenance Manual issue 10 is required to ensure continued Airworthiness.

8.9.2 LIMITATIONS

8.9.2.2 WEATHER (additional)

For Baskets K32T and K40Y fitted with burner frames without the symbol S/N before their serial number the maximum surface wind speed for take-off and landing is 5.5 ms⁻¹ (10.7 kts).

For Baskets K32T and K32Y when flown with envelopes of 6001 m³ to 7000m³ (211 to 247 000 ft³) the maximum surface wind speed permitted for take-off and landing is 5.5 ms⁻¹(10.7 kts).

8.9.2.3 FUEL

8.9.2.3.1 Fuel Pressures

Maximum admissible fuel pressure: 12 bar (174 psi).

Minimum admissible fuel pressure: 3 bar (44 psi).

When pressurising fuel cylinders with nitrogen care must be taken not to exceed 10 bar (145 psi)

CAUTION: Care should be taken if the fuel pressure is below 5.5 bar (80 psi) which reduces heat output of the burner. At low fuel pressure a balloon will be less responsive. The bigger the envelope the stronger this effect is. It is advisable to heat with both main and whisper burner to compensate for the decreased heat output.

8.9.2.3.2 Fuel Cylinders

When filling by weight the fuel weight must not exceed 0.42 kg/l of water capacity regardless of the fuel mixture used. (The cylinder weight must not exceed Full weight for Propane shown on the cylinder data plate).

WARNING: Fuel Cylinders must not be overfilled or heated by a direct flame. Kubicek cylinders must not be left in direct sunshine.

NOTE: The cylinder FLLG is set to 85% of the cylinder water capacity. Cameron cylinders use an FLLG set at approximately 80% of Water Capacity.

8.9.2.4 MINIMUM BURNER REQUIREMENTS

1. The burners may only be used with envelope volumes as below:

Burner Configuration	Permitted Envelope Volume
Sirius (One unit)	31450 ft ³ (890 m ³) - 140,000 ft ³ (3965 m ³)
Ignis Double (two units)	60,000 ft ³ (1700m ³) - 275,000 ft ³ (7788 m ³)
Ignis Triple (three units)	140,000 ft ³ (3970 m ³) - 375,000 ft ³ (10620 m ³)
Ignis Quad (Four units)	160,000 ft ³ (4531 m ³) - 600,000 ft ³ (16992 m ³)

2. Instrument Marking

Red Radial Line	Yellow Arc	Green Arc	Yellow Arc	Red Radial Line
Lower Limit	Significant Power Decrease	Normal Operation	Significant Flame Length Increase	Upper Limit
3 bar (44 psi)	3-4 bar (44-58 psi)	4-11 bar (58-160 psi)	11-12 bar (160-174 psi)	12 bar (174 psi)

Instrument markings and colour code meanings are shown for the burner pressure gauge.

8.9.2.5 PERMITTED DAMAGE

The balloon must not be flown without the burner support rods.

8.9.2.14 TETHERED FLIGHT (additional)

The maximum surface wind speed for tethered flight using Kubicek baskets must not exceed 7.8 Knots (4.0 ms⁻¹).

For Baskets K14, K28, K28H, K30PP, K32Y, K32TT, K40TTA, K50TT, K50TT8, K50TTA, K55X, K55TTA, K58H, K60X, K65TTA, K70, and K70TTA, Kubíček approved tethering components must be used.

8.9.2.15 BASKETS

6. The maximum number of occupants, maximum payload and approved envelope

volume of each variant of Kubiček basket is given in Table 6.

NOTE: The basket payload is the maximum weight the basket is allowed to carry. The weight limitation for the entire balloon remains unaffected.

7. Partitioned baskets must be fitted with an approved pilot restraint and may only be flown under an envelope fitted with turning vents.
8. Baskets fitted with a door may only be flown under an envelope fitted with Turning Vents.

WARNING: Door hinge pin(s) must be secured during the entire flight!
The door must be closed during the entire flight.

9. Baskets fitted with a passenger seat are neither covered nor approved by this supplement.

10. Baskets fitted with removable partitions:

- The partitions must be installed prior to balloon inflation and may not be moved or adjusted during inflation or in flight.
- No more than 6 people may be carried in any compartment.
- Each passenger must have within reach at least one hand hold in his or her compartment.
- When partitions are removed, passengers must be positioned so that not more than one person may fall on another during landing.
- A minimum floor area for each person of 0.25m² must be maintained regardless of arrangement of the partitions.
- The fuel cells may not be strapped to the non-woven partitions of the pilot compartment.
- Non-woven partitions are not considered as dividing the space. Any compartment(s) divided by non-woven partitions must be considered as a single compartment for calculation of the number of occupants.
- MTOW and MLW remain applicable.
- Any transverse pilot partitions (woven or non-woven) must be installed for flight.

WARNING: No operation with the pilot compartment partition removed is allowed.

CAUTION: Removing of partitions results in a lower maximum occupancy of the basket. Pay attention to observing the MLW and, mainly for “TT” baskets to an even distribution of weight.

11. Baskets with Lugs: The maximum wind speed for take-off using the quick release attached to the basket lugs is 4.0 ms⁻¹ (7.8 kts). The basket lugs **MUST NOT** be used for tethering.

8.9.2.18 EQUIPMENT INTERCHANGEABILITY

1. The burners, baskets and cylinders manufactured by Kubíček Balloons which may be used in combination with Cameron envelopes are listed in Section 8.9.9 of this supplement.
2. Approved Cameron Burner systems may be used in combination with Kubíček baskets where the burner is fitted in a compatible frame. Limitations specific to each burner assembly should be used (refer to base manual Section 2.4 and Supplement 8.22.2.4). A list of compatible frames is given in Section 8.9.9 of this supplement.
3. The Ignis Double Burner (two units) may be used in combination with Cameron Baskets when mounted in Cameron load frame CQ2018.
4. Subject to an assembly check, a Sirius or Ignis Double Burner fitted in a Basic frame may be fitted to any Cameron basket for which burner frame CB2203 is applicable.
5. 8-pole baskets (marked † in table 6) require a specific envelope flying wire set. Contact Cameron Balloons for details.

NOTE: Assembly Checks are described in Cameron Balloons Service Instruction No 21.

8.9.2.19 SMOKING

Smoking is not permitted in or within 30m (100 ft) of the balloon.

8.9.2.20 SPECIAL SHAPE BALLOONS

Special Shape envelopes may only be used with Kubicek baskets K10, K10S, K11, K12, K12A, K13, K13S, K14, K15, K16, K17, K19L, K22, K18, and K19.

In the case of conflict between the Limitations in the Special Shape Envelope Flight Manual Supplement and this Supplement (Weather, Minimum Burner Requirements etc.) the most restrictive limitations must be used.

8.9.2.21 Lindstrand and Sky envelopes

Lindstrand and Sky envelopes may only be used with baskets K10, K10S, K11, K12, K12A, K13, K13S, K14, K15, K16, K17, K19L, K22, K18, K19, K25P, K40Y, K60 and K70.

8.9.3 EMERGENCY PROCEDURES**8.9.3.10 Burner Failure (additional)**

Sirius Burner - Main burner valve (MBV) stuck open

Try to move the main burner lever, if still stuck then:

Shut off the fuel valve on the respective cylinder.

For heating use the whisper burner that is fed by fuel from another cylinder. That is the lever on the SAME SIDE of the burner as the blocked MBV.

Land as soon as practicable.

NOTE: The colour of the whisper burner control lever is the same as the colour coding of the hose that is feeding it.

CAUTION: NEVER use the second main blast valve when one MBV is blocked open. If the unaffected MBV is used propane will fill the fuel hoses of the affected side leading to a very slow shut-off of the burner.

8.9.4 NORMAL PROCEDURES

8.9.4.3 INFLATION

Pre-Inflation Checklist (additional)

Baskets	Basket door (if fitted) Closed and secured on both sides.
Removable Partition (if fitted)	Check its attachment to the basket floor and walls
Adjustable height burner frame (if fitted)	In lowest Position.
Ignis gyro (If fitted)	Check the tightness of the top bolt.

8.9.4.4 TAKE-OFF

8.9.4.4.1 Pre Take-Off Checks

Pre-Take-Off Checklist - Additional

Basket	Basket door (if fitted) Closed and secured on both sides.
--------	---

8.9.5 WEIGHT CALCULATIONS

No Change

8.9.6 BALLOON AND SYSTEMS DESCRIPTION

8.9.6.3 Burner

8.9.6.3.14 Ignis Burner

The Ignis burner is available as a double, triple or quad burner.

The main burners are fitted with blast valves that are operated by squeezing the control lever towards the hand grip.

The blast valve levers are arranged so that pairs of burners may be operated together by using one hand.

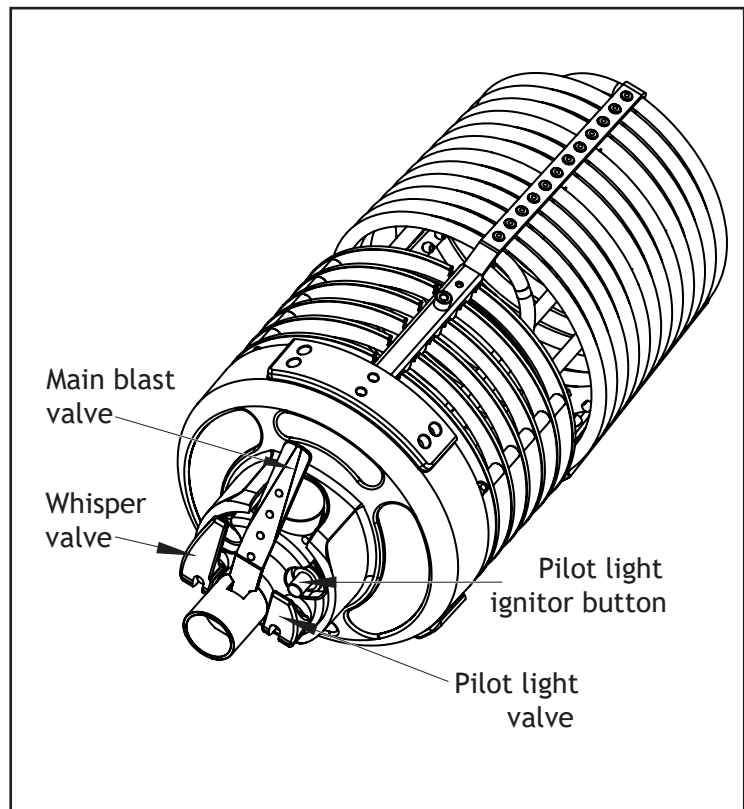

▲ Ignis Burner

The whisper burner is operated by a silver lever that is rotated downwards to open the valve.

The Ignis burner is fitted with either a vapor or liquid pilot light. The red pilot light lever covers the pilot light igniter when it is in the closed position. The pilot light lever is rotated downwards through 180 degrees to open the pilot light flame.

8.9.6.3.15 Sirius Burner

The Sirius burner is a single unit burner with all the features of a double. The main burner is fitted with two independent main blast valves that are operated by squeezing a control lever towards a hand grip. Each main blast valve controls fuel flow from one independent fuel source. The blast valve levers are arranged so that they may be operated together with the whisper burner levers by using one hand - one hand is operating a main blast valve fed by one fuel source and whisper burner valve fed by another fuel source at the same time. That offers better performance of the burner unit, because each burner is fed from independent fuel source and therefore can use maximum of the fuel pressure.

The whisper burner is operated by a red or green lever (colour is matching the colour mark on the corresponding fuel hose) that is rotated downwards to open the valve.

The Sirius burner is fitted with two liquid pilot lights. The red or green pilot light lever (colour is matching the colour mark on the corresponding fuel hose) covers the pilot light piezo igniter when it is in the closed position. The pilot light lever is rotated downwards through 120 degrees to open the pilot light flame.

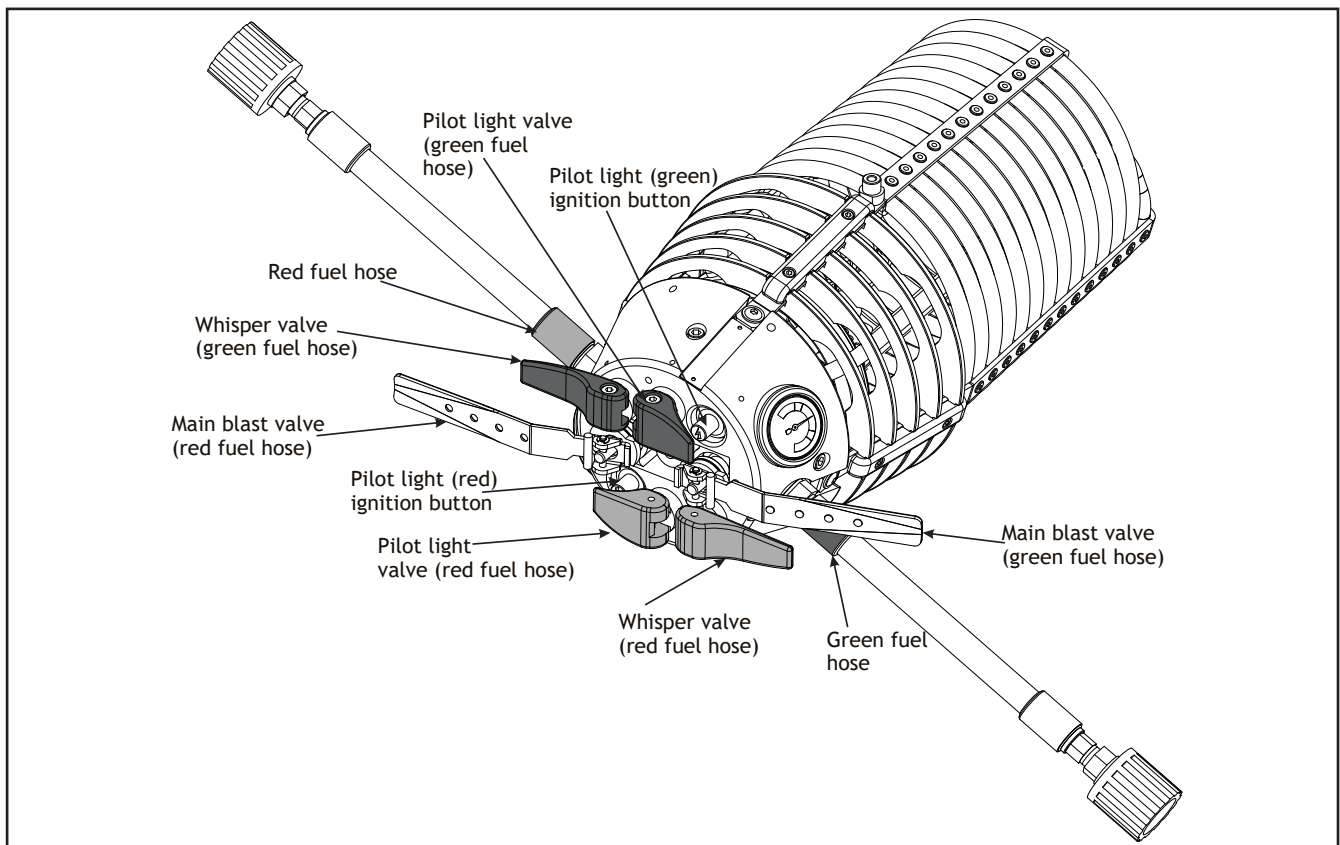

▲ Sirius Burner

NOTE: Do not open both the main blast valves at the same time, as the power cannot be increased this way.

8.9.6.5 BASKET

8.9.6.5.7 Tethering lugs

If required some baskets can be fitted with tethering lugs located on the steel upper frame. These lugs provide alternative attachment point for a quick release.

8.9.6.5.8 Basket Door

Basket door is optional equipment for the easy embarking and disembarking of passengers, mainly elderly or disabled persons. The door is to be open/closed only on the pilot's instruction prior to take-off and before the balloon has been released from the quick release and after landing.

The door and its frame structure is made of stainless steel tubes and wickerwork done in the same manner as the standard basket wall. The door is hinged on both sides. Securing the pins is provided by attaching the pin lugs to the door frame lugs with carabiners.

WARNING: Door hinge pin(s) must be secured during the entire flight! The door must be closed during the entire flight!

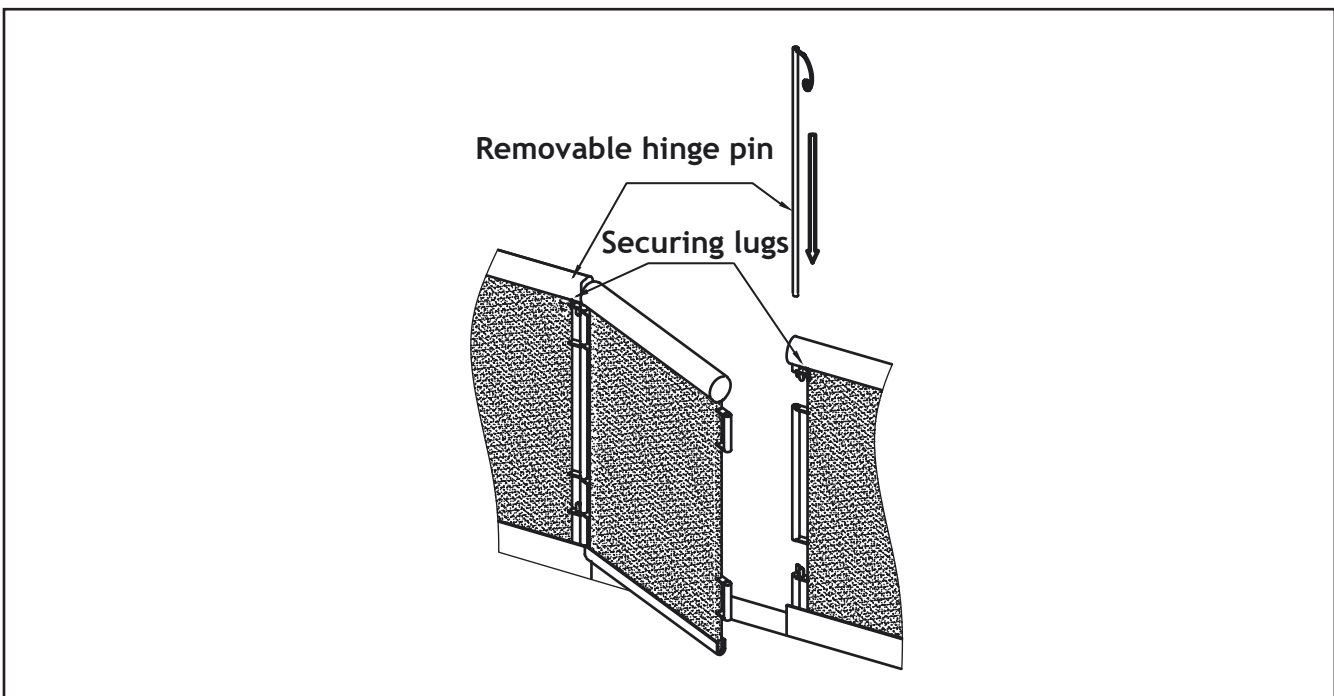

▲ Basket Door

8.9.6.5.9 Removable Partitions

A removable partition is an alternative to a classic, fixed, partition. It allows for an easy change of basket inner arrangement by removal or rotation. The structure of the

partition is made of stainless steel tubes. Wickerwork is done in the same manner as the standard basket wall. On the sides the partition attaches to the basket structure by a pair of hinges with continuous hinge pins so that the partition is attached along the entire height. Securing the pins is provided by attaching the pin lugs to the basket structure with carabiners.

The lower side attaches to the basket floor by bayonet locks.

Removable partition installation:

1. Insert the partition in a desired place.
2. Slide the partition sideways to correctly insert the floor pins into the locks.
3. Insert the hinge.
4. Secure all hinge pins with securing carabiners.

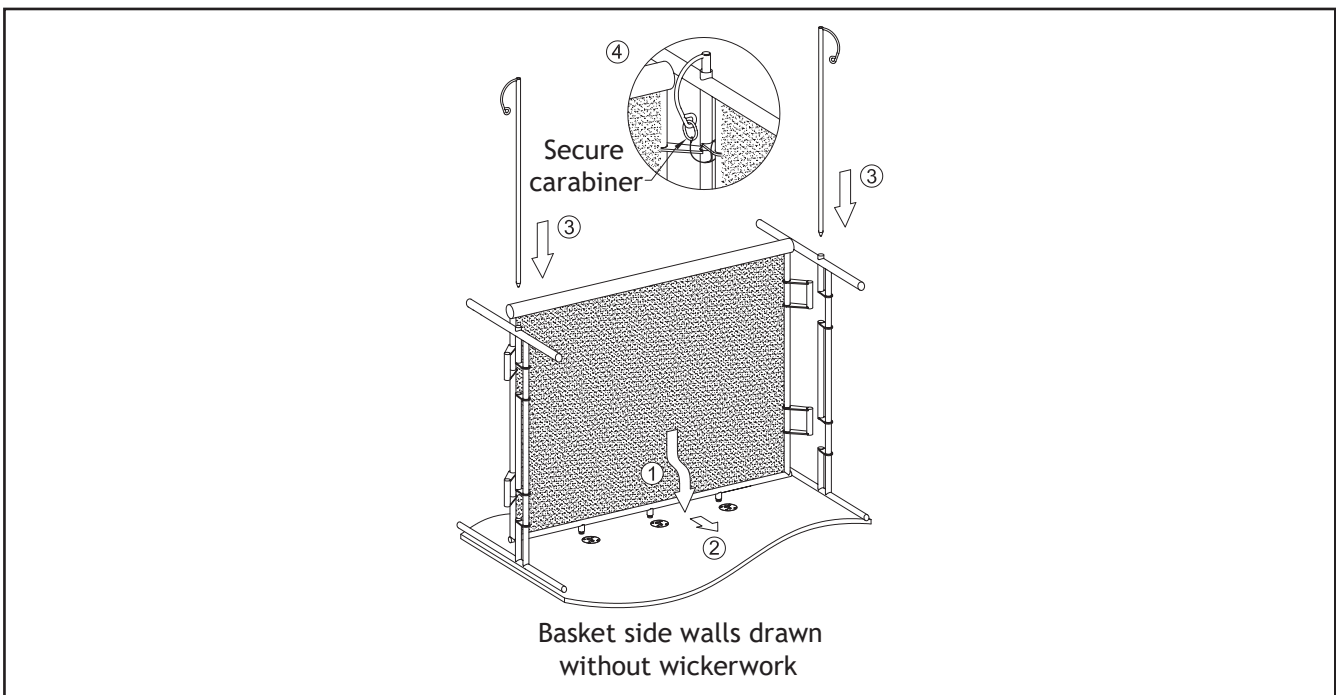

▲ Removable Partition

8.9.6.5.10 Non-Woven Pilot Partition

A non-woven pilot partition is an open framework without wicker which allows the pilot to pass through the partition into other compartments of the basket.

Cylinders must not be attached to a non-woven pilot partition.

Any transverse pilot partitions (woven or non-woven) must be installed for flight.

8.9.7 BALLOON MAINTENANCE, HANDLING AND CARE

For other information refer to applicable Kubíček Balloons Flight Manual.

8.9.9 EQUIPMENT LIST

Tables 6 and 8 list the Kubíček baskets and burners which may be used with Cameron envelopes.

Table 6: Kubíček Balloons Baskets (additional)

Basket Category	Drawing Number	Basket Description	Applicable Cylinders	Applicable Burner Frames	Max. Payload (kg)	Max. Occupancy	Approved Envelope Volume ***
B	K10*	56-65 O	1, 1a, 2, 3, 6	Fixed / Vario Frame - basic	600	3	56-105
B	K10S*	56-65 O	1, 1a, 2, 3, 6	Fixed / Vario frame - basic	455	3	56-105
C	K11*	56-65 O	1, 1a, 2, 3, 6	Fixed / Vario Frame - basic	650	3	56-105
D	K12*	77-84 O	1, 1a, 2, 3, 6	Fixed / Vario Frame - basic	700	4	60-105
D	K12A*	77-84 O	1, 1a, 2, 3, 6	Fixed / Vario Frame - basic	700	4	60-105
D	K13	77-90 O	1, 1a, 2, 3, 6	Fixed / Vario frame - basic	700	4	60-140
D	K13S	77-90 O	1, 1a, 2, 3, 6	Fixed / Vario frame - basic	550	3	60-140
E	K14	90-105 O	1, 1a, 2, 3, 6	Fixed / Vario frame - basic	800	5	70-140
E	K15*	90-105 O	1, 1a, 2, 3, 6	Fixed / Vario Frame - basic	800	5	70-140
F	K16*	90-105 O	1, 1a, 2, 3, 6	Fixed / Vario Frame - basic	900	5	77-150
F	K17*	90-105 O	1, 1a, 2, 3, 6	Fixed/ Vario Frame - basic	900	5	77-150
F	K19L	120-133 O	1, 1a, 2, 3, 6	Fixed / Vario frame - basic	950	6	77-150
F	K22	120-133 O	1, 1a, 2, 3, 6	Fixed / Vario frame - basic	980	6	77-150
G	K18*	120 O	1, 1a, 2, 3, 6	Fixed / Vario Frame - basic	950	6	77-150
G	K19*	120 O	1, 1a, 2, 3, 6	Fixed / Vario Frame - basic	950	6	77-150
H	K25P	140 T	1, 1a, 2, 3, 6	K25P	1000	8	133-210
H	K28	140 T	1, 1a, 2, 3, 6	K32T	1100	8	133-210
H	K30PP	140 P	1, 1a, 2, 3, 6	K30P	1100	10	133-210
H	K32Y, K32T	210-240 T	1, 1a, 2, 3, 6	K32T	1100	10	133-240
H	K32TT	210-240 TT	1, 1a, 2, 3, 6	K32TT, K50TT	1100	10	133-250
L	K40Y	210-250 T	1, 1a, 2, 3, 6	CB2505, CB2592, K40Y, K50	1200	12	160-300
L	K40T	210-250 T	1, 1a, 2, 3, 6	K50	1200	12	160-300
L	K40TTA	210-250 T Os	1, 1a, 2, 3, 6	K50	1200	12	160-300
M	K50	250 T	1, 1a, 2, 3, 6	K50	1400	14	160-300
M	K50TT	250 TT	1, 1a, 2, 3, 6	K32TT, K50TT	1400	14	160-300
M	K50TT8†	250 TT	1, 1a, 2, 3, 6	K60, K60 Strong	1400	14	160-350

Basket Category	Drawing Number	Basket Description	Applicable Cylinders	Applicable Burner Frames	Max. Payload (kg)	Max. Occupancy	Approved Envelope Volume ***
M	K50TTA†	250 TT Os	1, 1a, 2, 3, 6	K60, K60 Strong	1400	14	160-315
N	K55TTA†	275 TT Os	1, 1a, 2, 3, 6	K60, K60 Strong	1700	16	160-350
N	K55X†	275 T	1, 1a, 2, 3, 6	K60X	1700	16	160-350
O	K60†	300 TT	1, 1a, 2, 3, 6	K60, K60 Strong	1800	18	210-500
O	K60X†	300 T	1, 1a, 2, 3, 6	K60X	1800	18	210-500
P	K65TTA†	350 TT Os	1, 1a, 2, 3, 6	K60, K60 Strong	2500	20	160-350
O** or Q	K70†	350TT or 425TT	1, 1a, 2, 3, 6	K60, K60 Strong	3000	22	250-600
Q	K70TTA†	425TT	1, 1a, 2, 3, 6	K60, K60 Strong	3000	22	250-600

* These baskets are compatible, subject to an assembly check, with the following Cameron burner frames : A0/BFS/500A Series, CB855, CB871, CB925, CB2598, CB2224, CB2203, CB2231, CB2309, CB2874, CB2226, CQ2018, CB8810, B8811, CB8820, CB8821, CB8864, CB8894, CB8902.

** Serial numbers up to 399

*** Envelope volume in 1,000 cu.ft.

† These baskets use 8-pole frames and require a specific envelope flying wire set. Contact Cameron Balloons for details.

The SIRIUS burner may be installed on all baskets where a BASIC frame is specified.

Table 7: Fuel Cylinders (additional)

Cylinder Category	Cylinder Type	Cylinder Material	Volume (Litres)		Weight		
			Total	Usable	Empty kg	Full (Propane) kg	Full (LPG) kg
6	KB72L (Queen)	Duplex Stainless Steel	72	61	20	50	54
6	KB85L (Prince)	Duplex Stainless Steel	85	72	22	58	62
6	KB97L (King)	Duplex Stainless Steel	97	82	24	65	70

NOTE: Weights in this table are for load calculations only and must not be used for filling of the cylinders by weight.

NOTE: The weight for LPG must be used in the load calculations for any mixture of propane and butane.

Table 8: Kubíček Balloons Burners (additional)

Burner Category	Burner Model
A	Sirius (One unit)
B	Ignis Double (Two units)
C	Ignis Triple (Three units)
D	Ignis Quad (Four units)

Intentionally Blank Page