



## LINDSTRAND BALLOONS LTD

### MAINTENANCE MANUAL SUPPLEMENT NO. 2

## JETSTREAM SERIES 2 DOUBLE, TRIPLE AND QUAD BURNERS

### SECTION 1 - INTRODUCTION

This document describes the maintenance requirements for the Lindstrand Jetstream Series 2 Double, Triple and Quad burners.

### SECTION 2 - DEFINITION

The burners in the various configurations are defined by the following drawings:

BU-008-A-001	Double Burner Assembly (Toggle Action)
BU-008-A-002	Double Burner Assembly (Squeeze Action)
BU-010-A-001	Triple Burner Assembly (Toggle Action)
BU-010-A-002	Triple Burner Assembly (Squeeze Action)
BU-010-A-003	Triple Burner Assembly (Toggle with Crosslink)
BU-012-A-001	Quad Burner Assembly (Toggle Action)
BU-012-A-002	Quad Burner Assembly (Squeeze Action)
BU-012-A-003	Quad Burner Assembly (Toggle with Crosslink)

Due to the use of common components within the Double, Triple and Quad variants, the Double burner will be described. The general configuration of the Double burner when assembled in both toggle action and squeeze action modes may be seen in Figures 2.1 and 2.2 respectively.

### SECTION 3 - OVERVIEW

#### 3.1 General

The Jetstream Series 2 burner is based upon the Jetstream Series 1 burner, but incorporates some significant design changes. The more significant of these changes are detailed below:

- i) The Double burner incorporates a centre gimbal device with built-in anti-rotation stops and variable friction bearings.
- ii) The burners may be assembled with either toggle or squeeze action main valves, with the ability to retro-fit either version.
- iii) The crossflow unit provided when in the toggle version, is removable.
- iv) The valve blocks have been re-designed, simplifying the manufacturing and eliminating the necessity for blanking plugs.

However, the burner makes use of many of the sub-assemblies used in the Jetstream Series 1 burner.

#### 3.2 Main Vapourising Coil

One coil is fitted to each of the burner cans and is dedicated to the associated main burner. The coil construction and function are as described in Section 3.4.1.1. Note that the geometry of the feeders into the coil mounting boss has changed relative to that used on the Jetstream Series 1 burner and that coil assemblies are not interchangeable between Jetstream Series 1 and Jetstream Series 2 burners.





### 3.3 Liquid Fire Valves

The design and function of the liquid fire valves are as described in Section 3.4.1.2 of the Maintenance Manual (see Item 10, Figures 2.1 and 2.2).

### 3.4 Main Burner Valves

#### 3.4.1 **Main Burner Valves (Toggle Action)**

When the burner is configured in toggle action mode (see Figure 2.1), the function of the valve is as detailed in Section 3.4.1.2 of the Maintenance Manual.

#### 3.4.2 **Main Burner Valve (Squeeze Action)**

The basic design of the main burner valve when the burner is configured in the squeeze action mode (see Figure 2.2), is similar to that as described in Section 3.4.1.2 of the Maintenance Manual, with the exception that the valve handle is replaced with a cranked handle lever to facilitate the squeeze action.

With the exception of the cranked handle lever, the main valve is completely enclosed within the upper and lower valve posts which form the interface to the main crossbar handle.

### 3.5 Pilot Light Valve and Regulator

The design and function of the pilot light valves and regulators are as described in Section 3.4.1.3 of the Maintenance Manual (see Item 9, Figures 2.1 and 2.2).

### 3.6 High Voltage Ignition System

The design and function of the piezo igniters are as described in Section 3.4.1.4 of the Maintenance Manual (see Item 6, Figures 2.1 and 2.2).

### 3.7 Pressure Gauges

The design and function of the pressure gauges are as described in Section 3.4.1.5 of the Maintenance Manual (see Item 18, Figures 2.1 and 2.2).

### 3.8 Liquid Fire Nozzle

The design and function of the liquid fire nozzle are as described in Section 3.4.1.6 of the Maintenance Manual.

### 3.9 Triple Burner

The Jetstream Series 2 Triple burner is based upon the Double burner. The third, or slave burner, is positioned to form a delta shape. The burner is available with either toggle or squeeze action main burner controls, with optional crosslinks on the toggle version. However, the main burner valve on the slave is always a toggle.

The valve blocks used in the construction of the Triple are identical to those used on the Double burner, with the exception that each block has been spot faced to accommodate the tube stainless steel handles and that the slave valve block is fitted with a special crossflow blanking plate.

### 3.10 Quad Burner

The Jetstream Series 2 Quad burner is effectively two Double burners mounted adjacent to one another. The burner is available with either toggle or squeeze action main burner controls, with optional crosslinks on the toggle version.



As with the Triple burner, the Quad uses identical valve blocks to the Double burner, with the exception that each block has been spot faced to accommodate the burner handles.

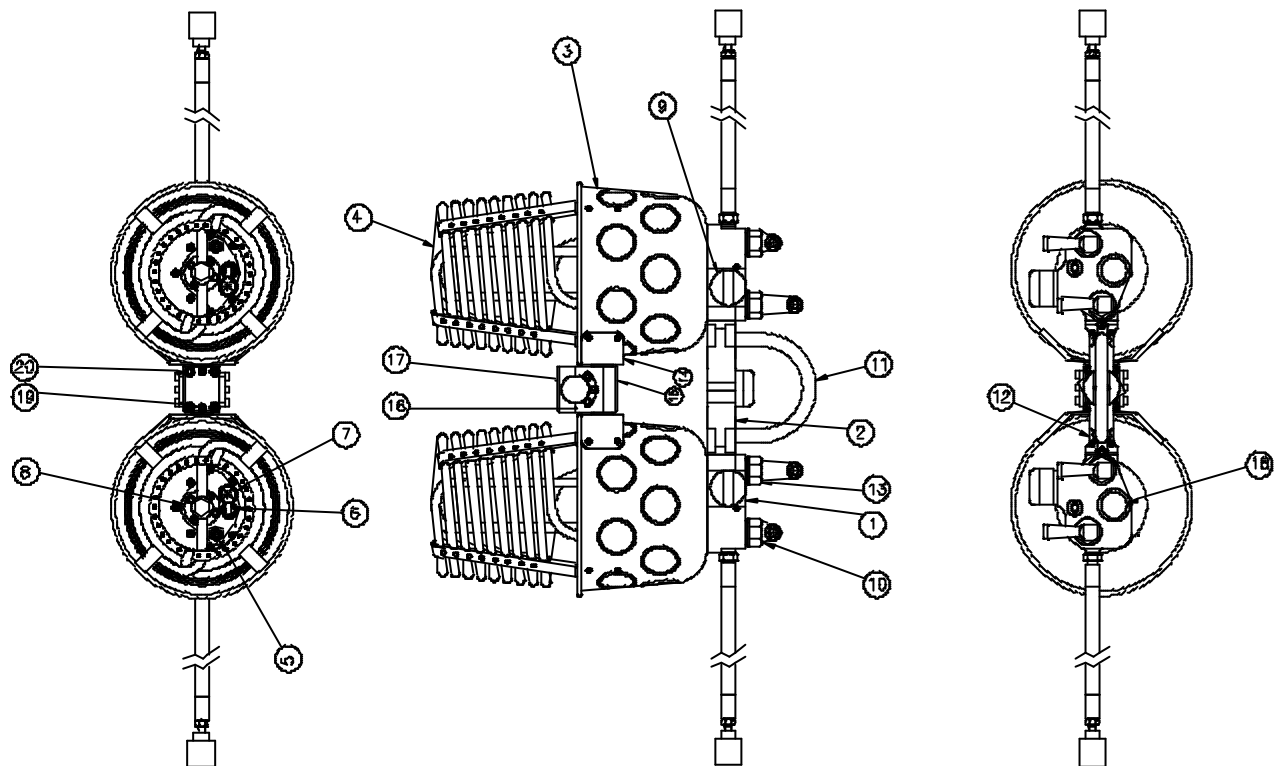

- 1 DOUBLE BLOCK ASSY
- 2 CROSSFLOW ASSEMBLY
- 3 BURNER CAN
- 4 COIL ASSEMBLY
- 5 LIQUID FIRE JET ASSEMBLY
- 6 IGNITER ASSEMBLY
- 7 PILOT LIGHT ASSEMBLY
- 8 COIL POST
- 9 REGULATOR ASSEMBLY
- 10 LIQUID FIRE VALVE ASSEMBLY

- BU-008-A-015
- BU-008-A-040
- BU-008-A-015
- BU-002-A-009
- BU-008-A-024
- BU-002-A-010
- BU-008-A-051
- BU-002-A-021
- BU-008-A-021

- 11 HANDLE ASSEMBLY (TOGGLE VARIANT)
- 12 COVER BLOCK
- 13 MAIN VALVE ASSEMBLY
- 14 SWIVEL ASSEMBLY
- 15 GIMBAL BLOCK CAP LOWER
- 16 GIMBAL BLOCK ASSEMBLY
- 17 GIMBAL BLOCK CAP UPPER
- 18 PRESSURE GAUGE ASSEMBLY
- 19 GIMBAL STIFFNESS ADJUSTMENT SCREW
- 20 GIMBAL MOUNTING SCREW

- BU-008-A-009
- BU-008-A-072, 073, 075, 076
- BU-008-A-022
- BU-008-A-008
- BU-008-A-067
- BU-008-A-014
- BU-008-A-066
- BU-008-A-023

FIG.2.1 JETSTREAM SERIES 2 DOUBLE BURNER (TOGGLE ACTION MODE)

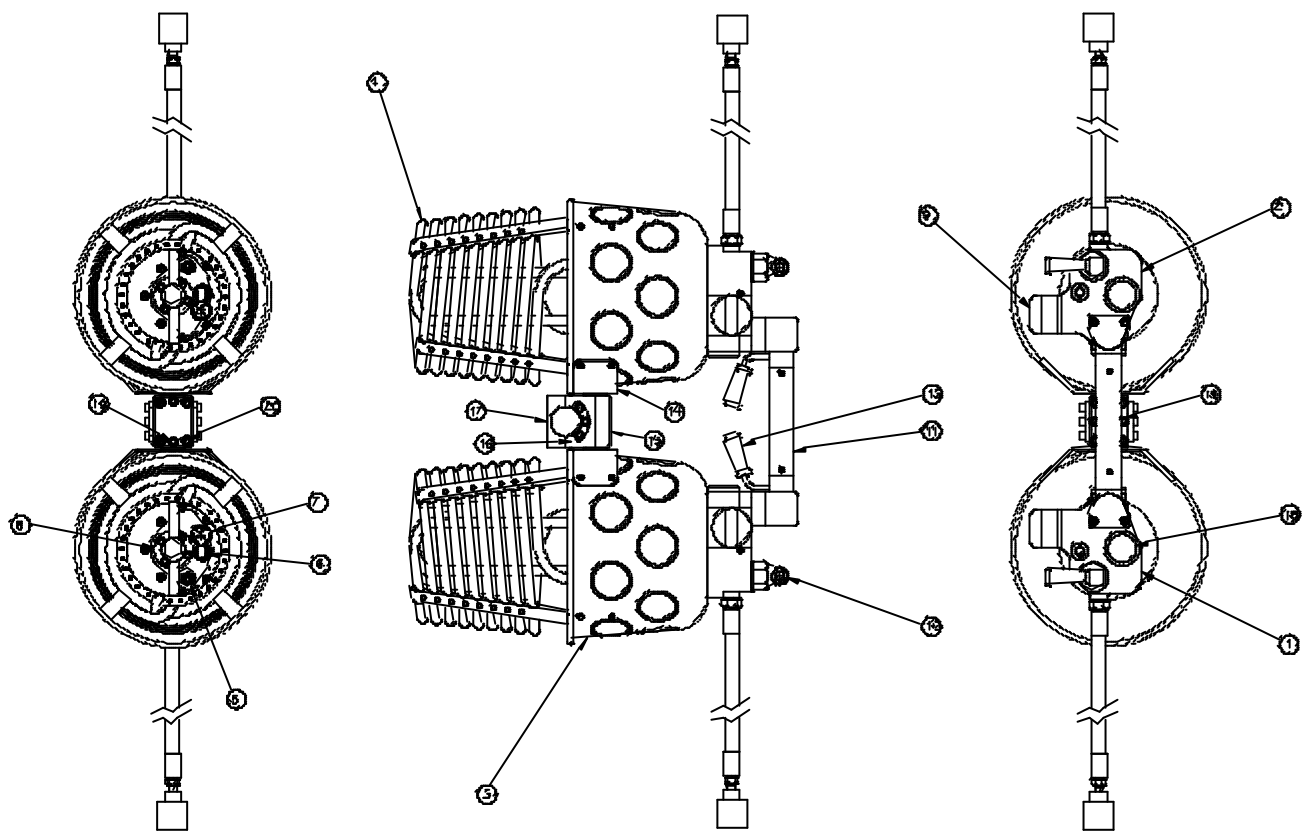

- 1 LEFT HAND VALVE BLOCK ASSY
- 2 RIGHT HAND VALVE BLOCK ASSY
- 3 BURNER CAN
- 4 COIL ASSEMBLY
- 5 LIQUID FINE JET ASSEMBLY
- 6 IGNITER ASSEMBLY
- 7 PILOT LIGHT ASSEMBLY
- 8 COIL POST
- 9 REGULATOR ASSEMBLY
- 10 LIQUID FINE VALVE ASSEMBLY

- BU-008-A-011
- BU-008-A-012
- BU-008-A-040
- BU-008-A-015
- BU-002-A-009
- BU-008-A-024
- BU-002-A-010
- BU-008-A-051
- BU-002-A-021
- BU-008-A-021

- 11 HANDLE TUBE
- 12
- 13 MAIN VALVE ASSEMBLY
- 14 SWIVEL ASSEMBLY
- 15 GIBBAL BLOCK CAP LOWER
- 16 GIBBAL BLOCK ASSEMBLY
- 17 GIBBAL BLOCK CAP UPPER
- 18 PRESSURE GAUGE ASSEMBLY
- 19 GIBBAL STIFFNESS ADJUSTMENT SCREW
- 20 GIBBAL MOUNTING SCREW

- BU-008-A-048
- BU-008-A-022
- BU-008-A-008
- BU-008-A-087
- BU-008-A-014
- BU-008-A-068
- BU-008-A-023

FIG.2.2 JETSTREAM SERIES 2 DOUBLE BURNER (SQUEEZE ACTION MODE)

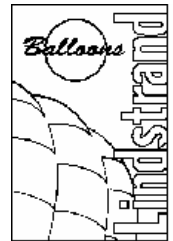

## SECTION 4 - PREVENTATIVE MAINTENANCE

### 4.1 Storage and Handling

Storage and handling requirements are similar to those defined in Section 4.5.1 of the Maintenance Manual.

### 4.2 General Cleaning

See Section 4.5.2 of the Maintenance Manual.

### 4.3 Jet Blockages

See Section 4.5.3 of the Maintenance Manual.

## SECTION 5 - REPAIR AND MAINTENANCE

### 5.1 General

The serviceable items within the burner are identical to those described in Section 5.4 of the Maintenance Manual, with the exception that some units are fitted in slightly different locations and certain components, as detailed below, have been re-designed:

Squeeze Action Main Valve  
Crossflow Blanking Plate Seal  
Crossflow Assembly Interface Seal  
Gimbal Stiffness Adjustment

Repair and maintenance of the burner is therefore as described in Section 5.4 of the Maintenance Manual, with the following exceptions.

### 5.2 Main Squeeze Action Valves

To remove the main squeeze action valves, proceed as follows:

Ensure that the burner is fully vented.

Using a 4 mm AF Allen Key, undo and remove the four hexagon drive cap head screws and crinkle washers, Items 14 and 16, Figure 5.2.

Using a 2 mm AF Allen Key, undo and remove the eight hexagon drive counter sink screws, Item 13, Figure 5.2.

Remove the handle tube, Item 2, Figure 5.2, from the upper valve posts, Item 3, Figure 5.2.

Remove the upper and lower valve posts.

Using a pair of circlip pliers, remove the circlip, Item 12, Figure 5.2.

Remove the pivot pin, Item 11, Figure 5.2, from the blast trigger cam. The blast trigger may now be removed. Take care to retain the spring and spring cap, Items 10 and 9, Figure 5.2, respectively, within the blast trigger cam.

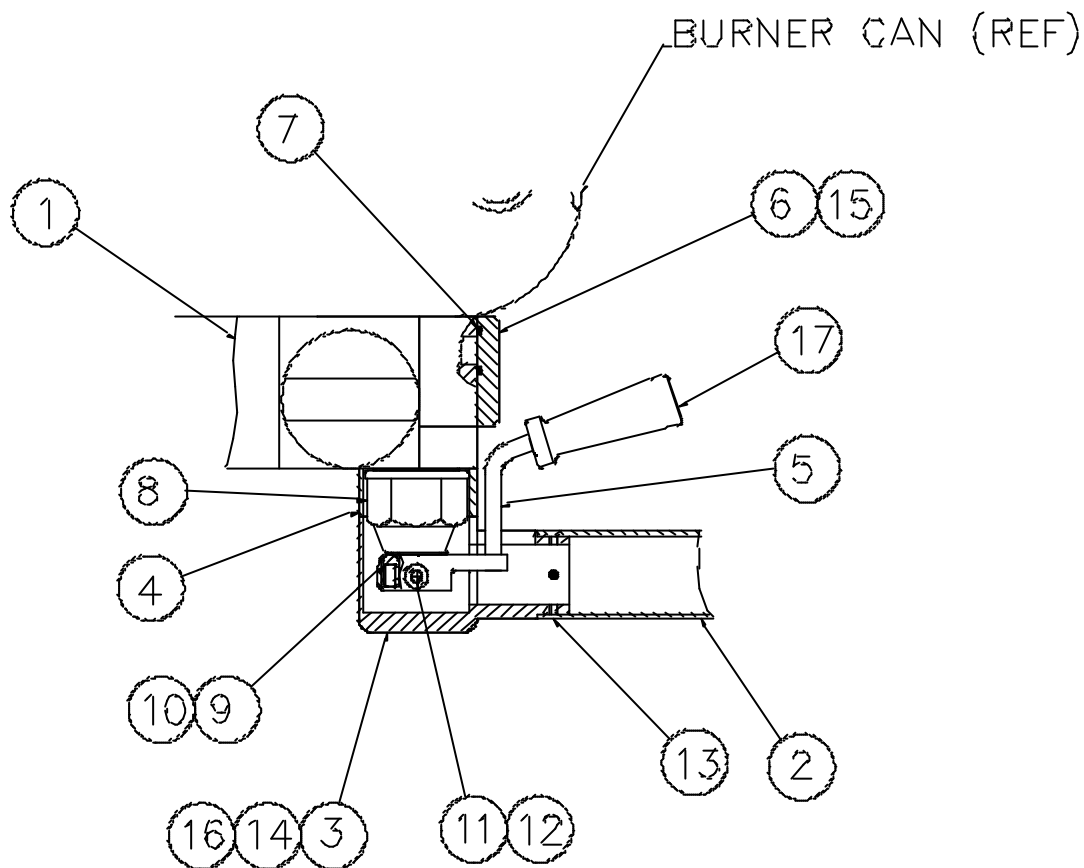

- |    |                        |              |
|----|------------------------|--------------|
| 1  | VALVE BLOCK ASSEMBLY   | BU-008-A-045 |
| 2  | HANDLE TUBE            | BU-008-A-042 |
| 3  | VALVE POST UPPER       | BU-008-A-043 |
| 4  | VALVE POST LOWER       | BU-008-A-010 |
| 5  | BLAST TRIGGER ASSEMBLY | BU-008-A-037 |
| 6  | BLANKING PLATE         | BU-008-A-054 |
| 7  | O SEAL                 | BU-008-A-016 |
| 8  | MAIN VALVE ASSEMBLY    | BU-008-A-074 |
| 9  | SPRING CAP             | BU290        |
| 10 | SPRING                 | BU-008-A-045 |
| 11 | PIVOT PIN              | BU2094       |
| 12 | CIRCLIP                | BU2978       |
| 13 | COUNTERSINK SCREW      | BU2980       |
| 14 | M5 CAP HEAD SCREW      | BU2200       |
| 15 | M6 CAP HEAD SCREW      | BU2980       |
| 16 | CRINKLE WASHER         | BU-008-A-048 |
| 17 | TRIGGER GRIP           |              |

FIG. 5.2 MAIN SQUEEZE ACTION VALVE



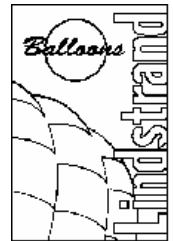

## 5.2 Main Squeeze Action Valves Cont....

Remove the main valve assembly, Item 8, Figure 5.2, from the valve block using a wide jawed adjustable spanner. It is recommended that the jaws are covered with masking tape to prevent scratch damage to the valve bonnet.

Remove the plastic wear pad from the recess in the top of the valve bonnet. Note that the wear pads are not always interchangeable between valve assemblies. It is recommended that only one valve assembly is dismantled at any time.

Further valve maintenance is as described in Section 5.4.2.2 of the Maintenance Manual.

Re-assembly is generally the reversal of the dismantling process. Always re-new the circlip. Apply Loctite 222 to the counter sink screws, Item 13, Figure 5.2, prior to re-assembly. Upon completion of re-assembly, pressure test the associated burner and test fire.

## 5.3 Crossflow Blanking Plate Seal

When the burner is configured in the squeeze action mode, the crossflow ports are blanked off using a specially machined aluminium plate and "O" seal. To replace the seal, proceed as follows:

Ensure that the burner is completely vented.

Remove the four cap head screws, Item 15, Figure 5.2, using a 5 mm Allen Key. The blanking plate may now be removed.

Carefully remove the "O" seal, Item 7, Figure 5.2, from the blanking plate "O" seal groove.

Do not use hard or sharp implements to remove the "O" seal, as this may damage the seal interface.

Check the "O" seal groove for any signs of damage or scratching. If any damage or scratching is detected, then the blanking plate must be replaced.

A new "O" seal must always be fitted on re-assembly. Prior to fitting the seal in the groove, lightly smear the seal with Molybdenum Disulphide grease.

Re-assembly is generally the reversal of the dismantling process. Apply Loctite 222 to the four cap head screws prior to re-assembly.

Upon completion of re-assembly, air pressure test the associated burner and test fire.

## 5.4 Crossflow Assembly Interface Seal

When the burner is configured in the toggle action mode, a crossflow assembly is fitted between the two valve blocks (see Figure 2.1). The crossflow assembly forms a pressure tight fuel link between the left hand and right hand burners. The seal is achieved with the use of an "O" seal, Item 7, Figure 5.4, at each end of the crossflow assembly. To replace the seal, proceed as follows:

Ensure that the burner is completely vented.

Remove the four cap head screws, Item 3, Figure 5.4, securing the handle assembly, Item 2, Figure 5.4, to the crossflow assembly, using a 4 mm Allen Key. (Note that the handle assembly is not fitted on the Triple and Quad versions).

Remove the hexagon drive counter sink screw, Item 4, Figure 5.4, securing each of the eight cover blocks, Item 5, Figure 5.4, using a 2 mm Allen Key. Remove the cover blocks.

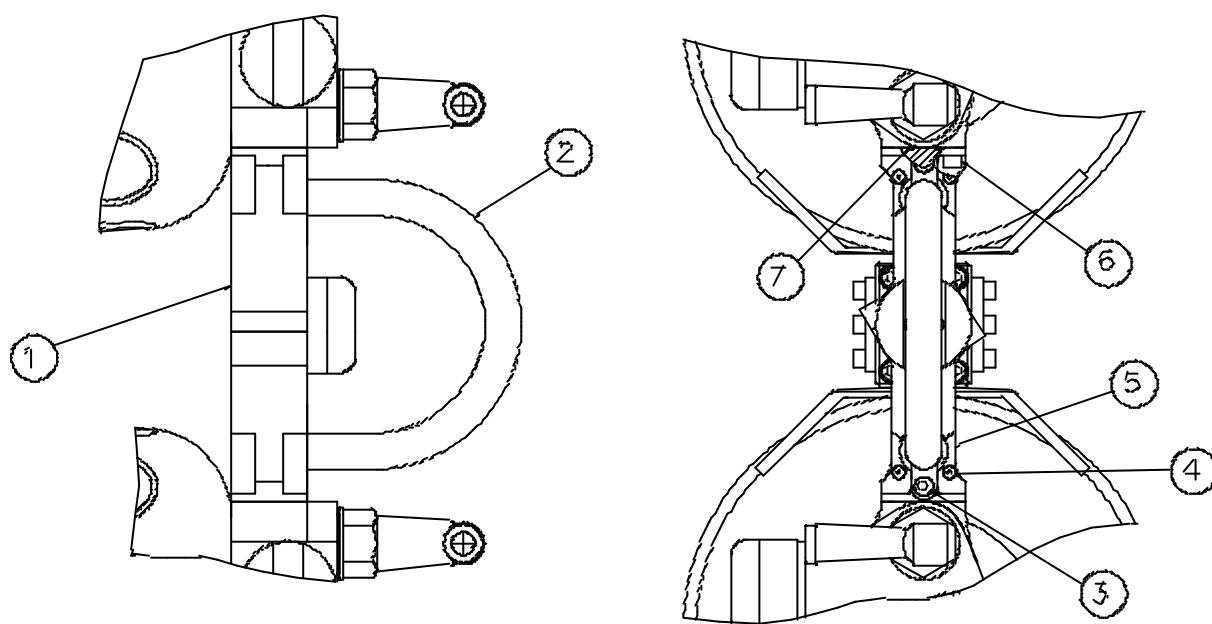

- |   |                             |                              |
|---|-----------------------------|------------------------------|
| 1 | CROSSFLOW ASSEMBLY          | BU-008-A-009                 |
| 2 | HANDLE ASSEMBLY             | BU2971                       |
| 3 | M5 CAP HEAD SCREW           | BU2989                       |
| 4 | HEX DRIVE COUNTERSINK SCREW | BU-008-A-072, 073, 075 & 076 |
| 5 | COVER BLOCK                 | BU2200                       |
| 6 | M6 CAP HEAD SCREW           | BU-008-A-054                 |
| 7 | O SEAL                      |                              |
| 8 |                             |                              |

FIG 5.4 PART VIEW SHOWING CROSSFLOW ASSEMBLY.



#### 5.4 Crossflow Assembly Interface Seal Cont....

Remove the eight cap head screws, Item 6, Figure 5.4, using a 5 mm Allen Key.

Carefully withdraw the crossflow assembly. Keep the crossflow assembly level as it is being withdrawn, to prevent it from jamming between the two valve blocks.

Carefully remove the "O" seals from each end of the crossflow assembly. Do not use hard or sharp implements to remove the seals, as this may damage the seal interface.

Check the "O" seal grooves and the valve block faces for any signs of damage. If any of the grooves or faces are damaged, they will need to be replaced.

New "O" seals must always be fitted on re-assembly. Prior to fitting the seals in the groove, lightly smear the seals with Molybdenum Disulphide grease.

Re-assembly is generally the reversal of the dismantling process. Apply Loctite 222 to the eight cap head screws prior to re-assembly.

Upon completion of re-assembly, air pressure test the complete burner assembly and test fire.

#### 5.5 Gimbal Stiffness Adjustment

The Jetstream Series 2 Double, Triple and Quad burners all utilise a central block to achieve the required gimbal action. The gimbal block is fitted with four phosphor-bronze bearings which may be adjusted to vary the gimbal action stiffness. To adjust the gimbal action stiffness, proceed as follows:

Make sure the burner is fully vented.

Using a 4 mm Allen Key, adjust the two cap head screws on the gimbal block cap lower, Item 19, Figure 2.2, a quarter turn each. Adjustment of these screws will vary the gimbal stiffness in the horizontal plane. Check the stiffness. Continue to adjust the screws a quarter turn each, until the required stiffness is achieved.

Adjustment of the gimbal stiffness in the vertical plane may be achieved by tightening or loosening the two cap head screws, Item 19, Figure 2.2, on the gimbal block cap upper, in a similar fashion.

