

# Alert Service Bulletin

**CAMERON  
BALLOONS**

**1. General** *This Service Bulletin is subject to CAA Airworthiness Directive number G-2004-0026*

(a) No.:	13
(b) Revision / Date	Revision 0 / Date 29/10/04
(b)Title:	Cracking of Weld on Triple and Quad Burner Mountings.
(c)Description:	Possible failure of weld at joint between the burner can support plate and mounting tube.
(d)Applicability:	All Shadow, Stealth and Stratus Triple/Quad Burner assemblies with gimbaled burners
(e)Effectivity:	All

**Note:** Applicability= All types and variants to which the change can be applied.  
Effectivity= Actual CN or group of CN's to which the bulletin has been/will be applied.

## **2. Background:**

There have been a number of failures during road transport of the weld between the burner can support plate and mounting tube due to insufficient weld bead/fatigue.

## **3. Compliance (Category):**

Inspection before next flight.

## **4. Consequences of Non-Compliance (Possible):**

Burner could become detached during flight.

## **5. Accomplishment Instructions:**

Inspect burner mounting bracket for security and correct appearance. Refer to Figure1. Non-conforming/cracked brackets must be replaced. Exchange brackets will be provided together with an instruction sheet for local replacement, or the burner can be returned to the factory. Refer to Cameron Balloons Ltd. for details.

## **6. Materials: Replacement Parts**

Shadow/Shadow Stealth - Triple Bracket - CB2216, Quad Bracket - CB2252.  
Stratus- Triple Bracket CB8592, Quad Bracket -CB8596.

## **7. Other Publications Affected: Not Affected**

## **8. Mass(Weight)/Balance: Not Affected**

## **9. Maintenance and Operating Instructions: Not Affected**

**10. Figure 1:**

Instructions.  
With the burner cold and all hoses disconnected/vented.  
1) Hold burner by top of coil and check for security of mounting.  
2) Visually inspect joint between burner can support plate and mounting tube. Check for visible weld bead.

Visible Weld Bead Here  
(Four positions on Quad Burner)

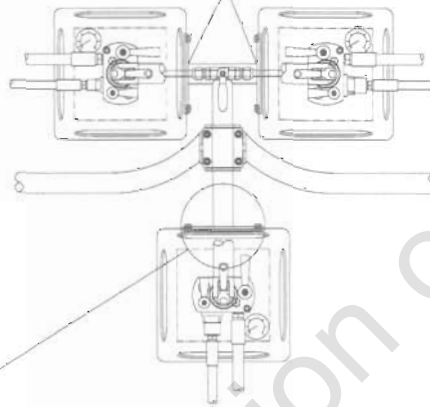

**Bracket With Correct Weld Bead**

**Bracket Without Correct Weld Bead**



Compiled by:

Notes:

Date: 29/10/04

Name: FJ Davies

**11. Design Organisation Approval:**

**Statement of Compliance Verification:**

I hereby confirm that this Alert is in compliance with all the applicable airworthiness requirements.

Signed, for and on behalf of Cameron Balloons Ltd.

*BE Bower*



Head of Airworthiness

Date: 29/10/04

Name: BE Bower